

CAT5 190/2 MODEL TWO FLOOR CHANNEL

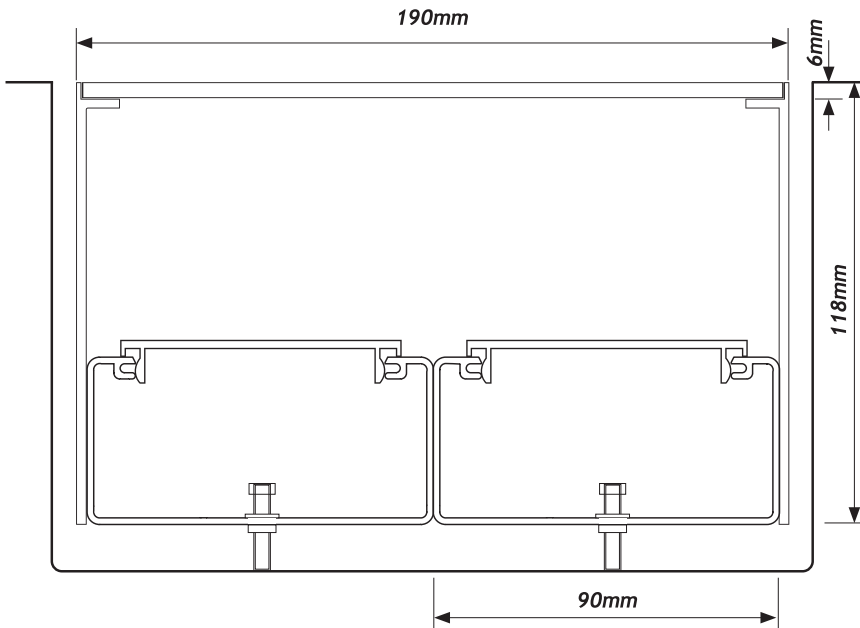

Double Compartment Floor Channel
 - CAT5/180/2 shown

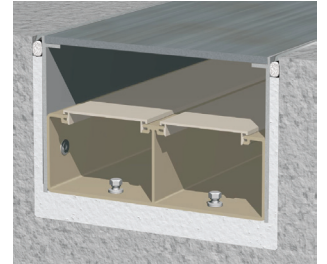

Sample image depicting an installed Model Two floor channel.

CAT 5 190.28.53
 MINIMUM DEPTH & CONFIGURATION

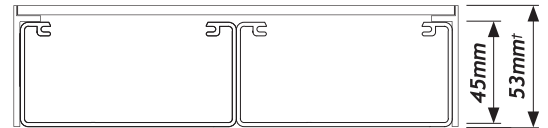

CAT 5 190.28.118
 STANDARD DEPTH & CONFIGURATION

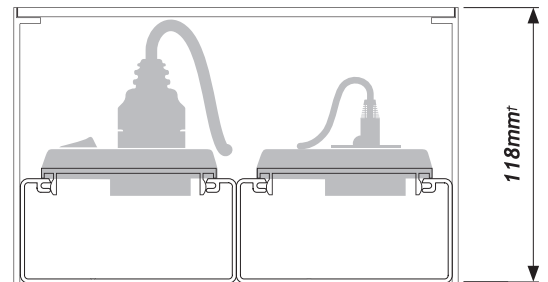

CAT 5 190.28.200
 MAXIMUM DEPTH & CONFIGURATION

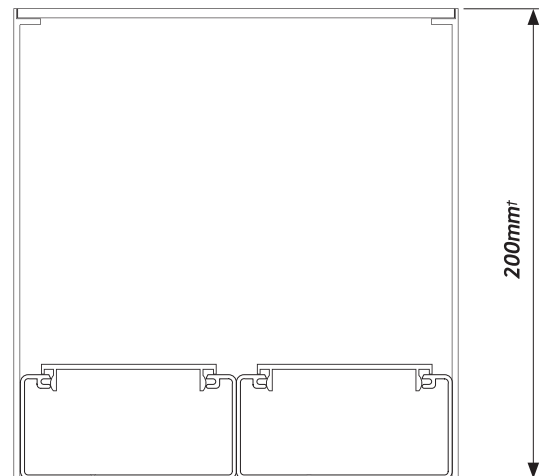

† Recess depth and width will be subject to your site environment. Refer overleaf to fig.1 item A

Varying channel depth (200mm max.) options available.

Contact Interserv to discuss your needs.



0800 828 914

15 Patiki Road, Avondale, Auckland, NZ

www.interserv.co.nz

CAT 5 190/2* MODEL TWO DUAL FLOOR CHANNEL ACCESSORIES

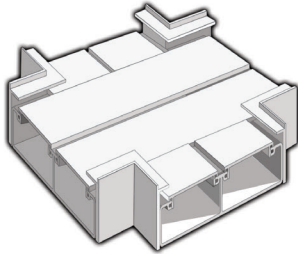

4 Way intersection

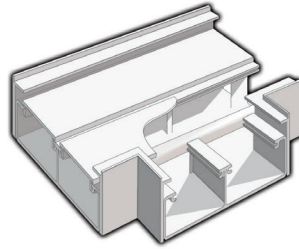

T intersection

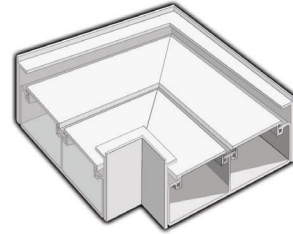

Flat Bend intersection

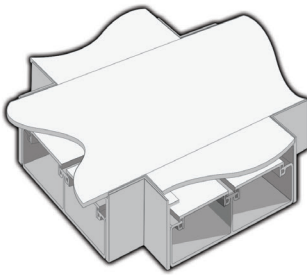

Floor channel capping configurations

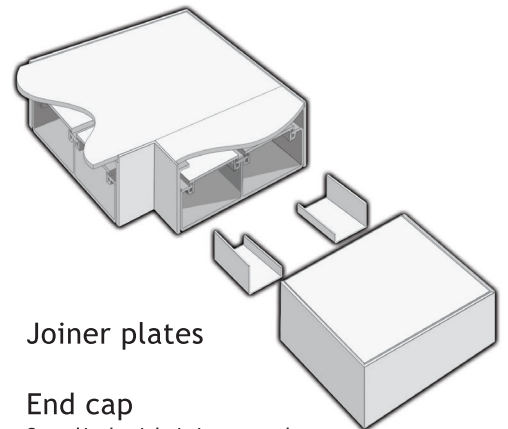
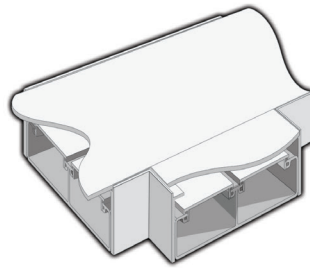

Joiner plates

End cap
Supplied with joiners and
fixing hardware

FLOOR CHANNEL ACCESS OPTIONS

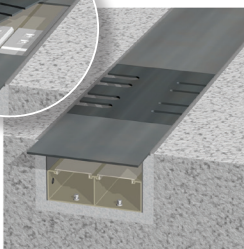
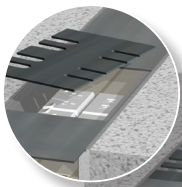

Basic lift out



Hinged at side rail

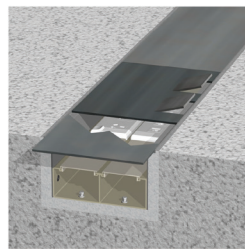

Cutaway cable egress



*IMAGES ARE NOT TO
SCALE / PROPORTION

0800 828 914

15 Patiki Road, Avondale, Auckland, NZ

www.interserv.co.nz

Floor Channel Installation:

QUALIFYING CONCRETE FLOORING CONDITIONS

MODEL TWO

The sample imagery depicts CAT 6 180/2 however the majority of Interserv Floor Channel profiles will employ this installation procedure.

Fig.1

A. Establish a trench 10-20mm[†] wider than the profile (5-10mm each side) and 10-20mm* deeper.

[†] Channel clearance can vary dependant on accuracies and tolerance of your particular application and your desired gap fill, i.e. a soft fill seal indicated in Fig.3.

*Depth depends on required height level of the aluminium cover plate after projected floor coverings are placed.

B. Use the screws in the profile rivnuts to adjust the levels of your floor channel.

Once the uniform height of the entire floor channel is set by the adjustment screws, lift the floor channel clear of the trench.

Fig.2

Pour in the necessary amount of grout to provide a solid bed for the floor channel.

C. Push the floor channel back down into the trench to the limits of the prior-adjusted screws.

Fig.3

Pushing the channel down will displace some grout up the side walls of the floor channel and the trench wall.

D. Soft seal to floor level the side wall gaps with foam caulking product and finish with a silicon product for your desired finish.

[†] Varying channel depth (200mm max.) options available.
Contact Interserv to discuss your needs.
Follow the installation process for all sizes.

Fig.1 Set heights then remove channel

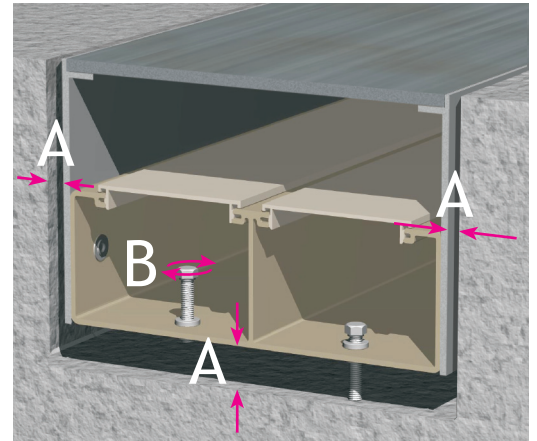

Fig.2 Pour then push channel into grout

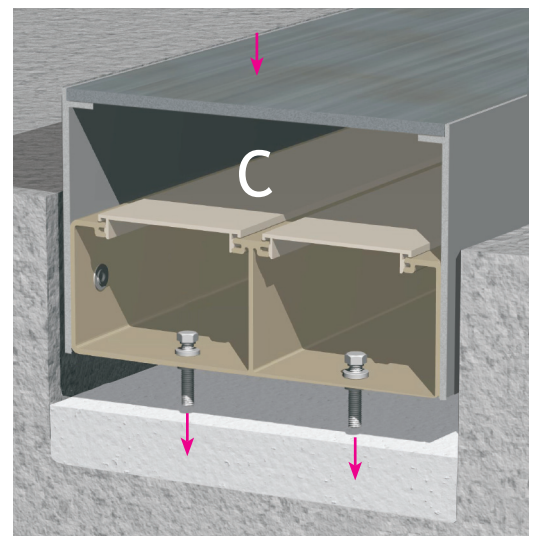

Fig.3 Soft seal the side gaps

